



PORTALP

ISO3 OPERATOR

Electromechanical operator for swing doors

UNIVERSAL PRODUCT

EASY INSTALLATION

EMERGENCY EXIT
Public establishments (ERP)



FIRE SAFETY
Force EN3 to EN6



A user friendly operator for a number of applications.

ISO 3 is the ideal choice for all applications that require:

- Power and management for high traffic
- Safety of people and buildings in accordance with applicable regulations
- Flexible and soft opening for the elderly and handicapped
- Comfortable and clean for access in sensitive areas



PAGE ELECTRIC

ISO3 A multitude of applications, a single operator

NEED +

LOW ENERGY MODE



NURSING HOMES, HOMES FOR ELDERLY PEOPLE ...

Bring comfort and safety to your residents, providing assistance to the elderly for whom opening a door is sometimes difficult or tricky.

NEED +

MANAGING OVERPRESSURE IN STERILE ENVIRONMENT



HOSPITALS, CLINICS, PRESERVE HEALTH IN YOUR INSTITUTION WHILE FACILITATING EASY MOVEMENT IN THE CORRIDORS .

In a medical environment, cleanliness and hygiene are vital. It is a major challenge to limit the contamination of door handles by hand contact.

ISO3 DELIVERS EFFICIENCY AND PERFORMANCE IN ALL SCENARIOS.



OPERATING TYPES

- Fully Automatic
- Power Assisted
- Push and Go

OPERATING MODES

- Auto/Open/Closed/Entry/Exit/Manual

STANDARDS

- Low Energy
- EN16005
- ANSI 156.19
- EN3-EN6. fireproof

PROGRAMMING

- Programmable Inputs/Outputs
- Diagnostics

TYPES OF ELECTRIC LOCKS

- Motorized locks
- Electric strikes
- Door holders ...

ZOOMS

CLOSE-DOOR FUNCTION

By return spring

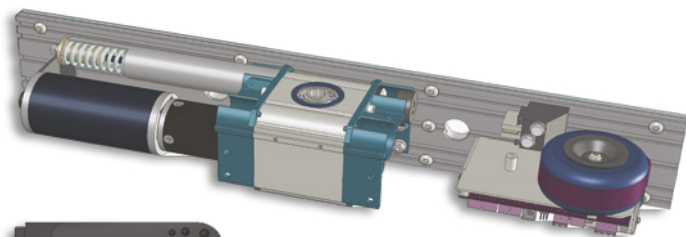

3- POSITION SELECTOR

- Open/Auto/Manual
- Reset button
- Door status signaling (Diagnostics)

All types of opening control, safety and locking systems are possible, depending on usage, access issues (high traffic, elderly & handicapped) and environmental constraints (hygiene, cleanliness, wind, pressure, etc.).



- Radars and detections
- Opening controls with or without contact
- Key mode selector
- Console for switching mode and user settings



NEED +

SAFETY OF PREMISES

Managing many types of locking



PUBLIC AND ADMINISTRATIVE BUILDINGS,
SHOPS, HOTELS, RESTAURANTS ...

Traffic density here is often very high. Both users and operators appreciate automatic doors that can be opened smoother and more safely.

NEED +

MANAGING INTENSE TRAFFIC



AIRPORTS,
QUICK AND SAFE ACCESS.

At airports, the speed of movement of passengers is a key performance factor. The ability to adapt to all conditions (including climate) is an added advantage.

MECHANICAL	PUSHING	FIRE RATED PUSHING	PULLING
Assembly	Horizontal on door frame, right or left		
Dimensions (H x D x L)	102 x 136 x 650 mm	102 x 136 x 760 mm Telescopic	102 x 136 x 650 mm
Arm	compass arm - satin black finish		Guide rail arm, satin black
PERFORMANCE			
Max. opening angle	120°	95°	95°
Min/max. leaf width	Single: 720 - 1,500 mm Double: 1,450 - 3,000 mm	Single: 780 - 1,400 mm Double: 1,500 - 3,000 mm	Single: 820 - 1,500 mm Double: 1,550 - 3,000 mm
Max. weight*	250 kg (width 0,8m)*	250 kg (width 1,1m)*	160 kg
Pulling door - closer power	160 kg	EN 3 to EN 6 according to EN 61937-2 / EN1154	100 kg
Vertical adjustment	Operator base - Passage height H.: 0 - 50 mm / H.: 50 - 100 mm		Operator base - Door height H.: 45 - 95 mm H.: 95 - 145 mm
Horizontal adjustment	Lintel depth P.: 0 - 200 mm P.: 200 - 400 mm (optional)		Wall plate / wall P.: ±10 mm
Adjustable speeds	Opening : 10 to 60°/s Closing : 10 to 50°/s		
Hold opening time	0 to 25 s		
Sound level	3 hold times: Complete opening, Master-slave partial opening, Priority opening 55 dBA measured from a distance of 25 cm		

ELECTRICAL ENVIRONMENT	
Power supply	230 V AC/120 V AC, 50/60 Hz ±10 % with earth
Consumption	At rest 10 W - Max. 120 W
Humidity rate	10 % to 85 % without condensation
Operating temperature	-20° C to +60° C
Lock control	12 VDC or 24 VDC/12 W max.
Standards	EC - EN 61000 6-3 - EN 61000 6-2 - EN 16005/IS - UL325 EN 60335 - EN 13849-1 NFS 61937-1 - NFS 61937-2

FEATURES	
<ul style="list-style-type: none"> Push & Go Master - slave leaf synchronization Airlock door management Management of doors in overpressure or in negative pressure Reset Programmable inputs: <ul style="list-style-type: none"> - 2 inputs Closing/Opening safety NO/NC/Self - controlled - 1 control input Internal NO/NC/Frequency - 1 control input External NO/NC - 1 input Key/Priority opening - 1 input 6P/3P selector 	<ul style="list-style-type: none"> 6 operating modes Code management Fault diagnostics/history Cycle counter Programmable outputs: <ul style="list-style-type: none"> - 2 relay outputs Travel Limit Open/Travel Limit Close/ Technical alarm/Person with reduced mobility - 1 locking output: Inrush current/No current Stationary/Motorized

EQUIPMENT / OPTIONS			
3-P selector	●	Pushing shaft extension 50 - 100 mm	○
6-P selector	○	Pulling shaft extension 95 - 145 mm	○
Naviblu console	○	Fire detection module (Actuated Safety Devices)	○
Reset button	●	Master - slave connecting cable	○
Pushing arm slide 200 - 400 mm	○	Pulling arm FBO equipment	○

FINISH / CUSTOMIZATION			
ASI finish	●	Customized single cover	○
RAL finish	○ ON	Customized double cover	○
Special finish	REQUEST	Double-door intermediate cover	○

● Standard ○ Optional

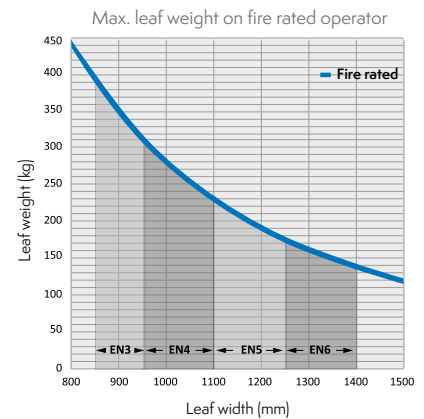
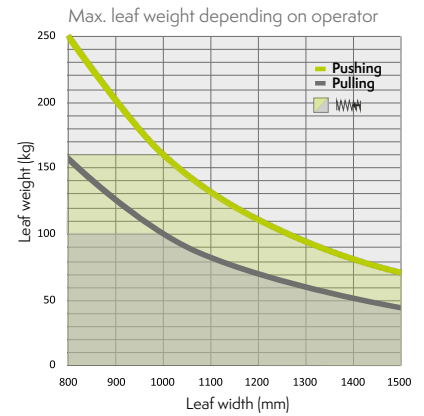

GREATER INSTALLATION FLEXIBILITY

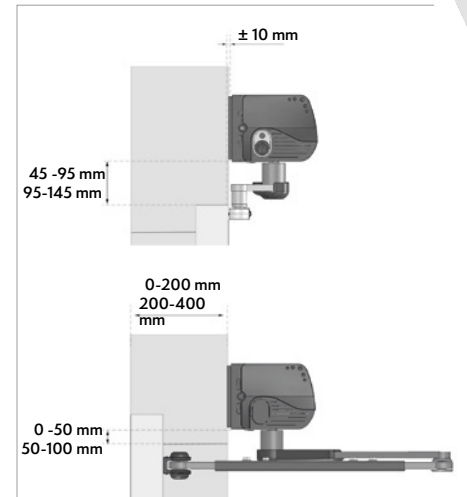

www.pageelectric.ie

sales@pageelectric.ie

01 2989781



Certified Management System